

 **OPERATING INSTRUCTIONS**

Evaporative humidifier

B 200



PLEASE READ THESE OPERATING INSTRUCTIONS CAREFULLY BEFORE STARTING ANY WORK!



Use and storage of the instructions

Read these instructions carefully before operating the Brune B 200 evaporative humidifier. Failure to observe these instructions may result in injury or damage to the humidifier or the installation site. Keep these instructions in a safe and accessible place near the appliance. If you pass the humidifier on to a third party, also pass on the operating instructions. Illustrations in these instructions are for basic understanding and may differ from the actual design.

Note on commissioning

The prerequisite for safe working is compliance with all the specified safety instructions and operating instructions. To put the humidifier into operation, it must be connected to the power supply and the water tank must be filled (↪ see chapter „3.2 Preparing the humidifier for operation“ on page 10).

Notes on cleaning and care

To ensure optimum operation, the evaporation filter and combination cleaning filter must be changed regularly. Regular water changes and cleaning of the water tank and the inside walls of the appliance are necessary to avoid creating conditions conducive to the formation of germs (↪ see chapter „4. Cleaning and care“ on page 15).

Accessories

The following accessories are available for the Brune B 200 evaporative humidifier from Brune Luftbefeuchtung Proklima GmbH:

- Water fresh / Item no.: 9020, 9022
- Limescale remover / Item no.: 9016
- Evaporation filter / item no.: 2090
- Combi cleaning filter / item no.: 2080
- Pads for Aroma Box / Item no.: 2070

Copyright protection

The contents of these instructions are protected by copyright. Their use is permitted within the scope of using the appliance. Any other use is not permitted without the written permission of Brune Luftbefeuchtung Proklima GmbH.

Customer service

Address BRUNE
Luftbefeuchtung Proklima GmbH
Schwarzacher Straße 13
D-74858 Aglasterhausen

Phone number +49 (0) 6262 / 54 54
fax +49 (0) 6262 / 32 55

e-mail mail@brune.info

Table of contents

1. Product description	4
1.1 Humidifier overview	4
1.2 Operating and display elements	5
1.3 Technical data	6
2. Security	6
2.1 Symbols in these instructions	6
2.2 Intended use	7
2.3 Dangers posed by the humidifier	7
2.4 Environmental protection	9
3. Transporting and commissioning	9
3.1 Transport and set up	9
3.2 Preparing the humidifier for operation	10
3.3 Putting the humidifier into operation	11
4. Cleaning and care	15
4.1 Maintenance table	15
4.2 Opening and closing the intake grille	15
4.3 Changing the combi cleaning filter	17
4.4 Remove tank	17
4.5 Changing the evaporation filter	18
4.6 Changing the water and cleaning the appliance	19
6. Solve problems	20
7. Spare parts	20
8. Type plate	21
9. Disposal	21

1. Product description

1.1 Humidifier overview

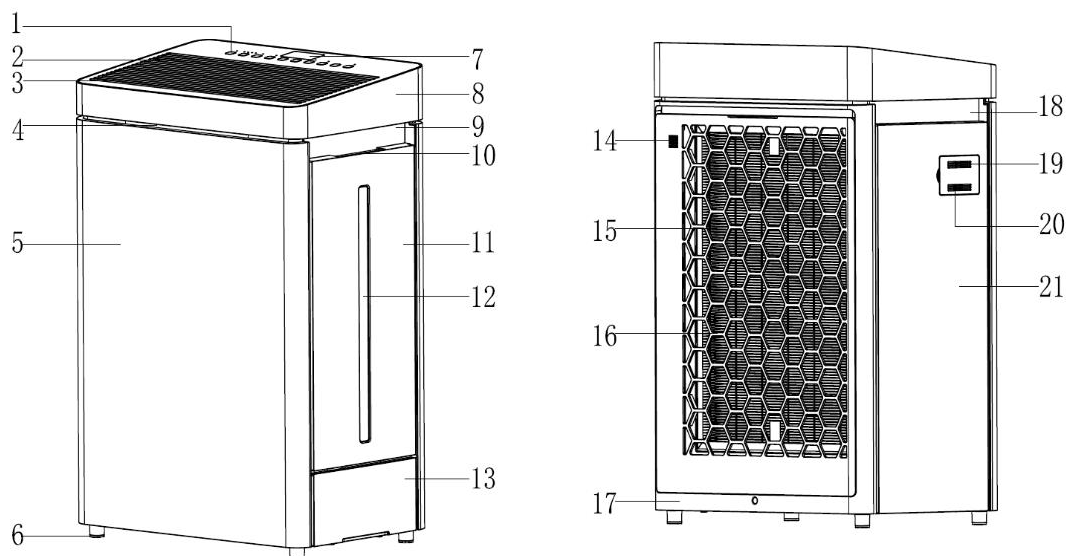

Fig. 1.1.1: Humidifier overview (left: side view; right: rear view)

- | | |
|--------------------------|------------------------------------|
| 1. Control panel | 11. Portable water tank |
| 2. Discharge grille | 12. Water tank indicator |
| 3. Upper left part | 13. Drip tray |
| 4. Air quality indicator | 14. Combination cleaning filter |
| 5. Front cover | 15. Intake grille incl. pre-filter |
| 6. Feet | 16. Rear cover |
| 7. Display | 17. Left handle |
| 8. Upper right part | 18. Air quality sensor |
| 9. Right handle | 19. Sensor cover |
| 10. Tank handle | 20. Left cover |

Function







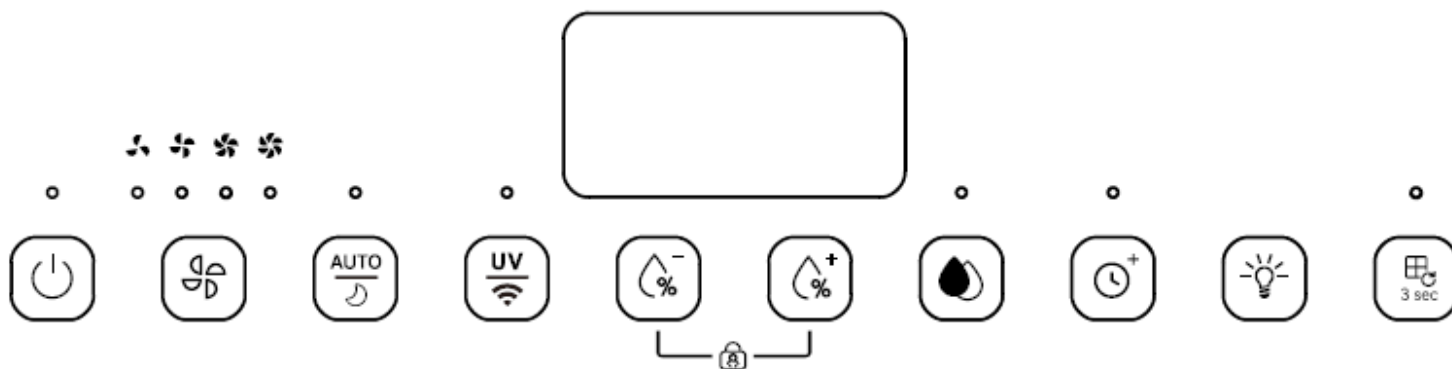



The humidifier works on the principle of evaporation. This means that the internal evaporation filter in the filter carrier is moistened and absorbs the moisture. The fan draws in the dry room air through the intake grille, filters it through the pre-filter and combination cleaning filter and humidifies the air through the evaporation filter. The purified and humidified air is then released back into the room through the discharge grille at the top.

1.2 Operating and display elements

Operation



Control elements

Icon	Description	Operation
	STANDBY / ON / OFF	■ Switch the humidifier on and off.
	Fan	■ Select the fan speed.
	Auto mode / Silent mode	■ Switch on auto mode. ■ Switch on silent mode.
	UV Light Mode / WiFi	■ Switch on the UV lamp. ■ Switch on WiFi.
	Humidity -	■ Decrease air humidity.
	Humidity +	■ Increase air humidity.
	Humidifier mode	■ Switch on humidifier mode.
	Timer	■ Set the timer.
	Display OFF	■ Switch off the display.
	Filter control reminder	■ Reset filter control reminder

1.3 Technical data

Specification	Value	Unit
Empty weight	11,25	kg
Width	420	mm
Height	644	mm
Depth	280	mm
Total tank volume	approx. 8	l
Mains connection	230	V
Mains frequency	50	Hz
Power consumption	55	W

Operating conditions

Specification	Value	Unit
Temperature	5 - 41	°C
Relative humidity	20 - 80	%

2. Security

This section provides an overview of all important safety aspects for the protection of persons and for safe and trouble-free operation. Further task-related safety instructions are contained in the sections on the individual life phases.

2.1 Symbols in these instructions

Safety instructions

Safety instructions in this manual are identified by symbols. The safety instructions are introduced by signal words that express the extent of the hazard.

**DANGER!**

This combination of symbol and signal word indicates an imminently hazardous situation which, if not avoided, will result in death or serious injury.

**DANGER!****Danger to life from electric current!**

This combination of symbol and signal word indicates an imminently hazardous situation which, if not avoided, will result in death or serious injury from electric shock.

**WARNING!**

This combination of symbol and signal word indicates a potentially dangerous situation that can lead to death or serious injury if not avoided.

**NOTE!**

This combination of symbol and signal word indicates a potentially hazardous situation which, if not avoided, may result in damage to the environment and property.

2.2 Intended use

The B 200 evaporative humidifier is designed exclusively for humidifying and purifying room air in a private environment and is not suitable for use in the medical sector.

Intended use also includes compliance with all the information in these instructions.

Any use beyond the intended use or any other use is considered misuse.

Hygienic operation

When operated with clean fresh drinking water and in accordance with this manual, the device is safe to use for humidification in private households. However, drinking water contains bacteria and microorganisms. To ensure hygienic and faultless operation of the humidifier, regular water replacement and cleaning is essential. Failure to do so may cause health problems. Therefore, always follow the cleaning instructions and keep your appliance clean and fresh.

Misuse



WARNING! **Danger of misuse!**

Misuse of the B 200 evaporative humidifier can lead to dangerous situations, damage to the appliance or to furnishings.

- Only fill the humidifier with fresh, ordinary tap water (max. 150 CFU/ml).
- Do not add essential oils or other flammable liquids.
- Only use additives approved by Brune.
- Only use filters approved by Brune.
- Do not use any fragrances or flavorings outside the Aroma Box and only in small quantities.
- Never cover the appliance.
- Never place objects on the humidifier. This applies in particular to electrical appliances or containers filled with liquid.
- Do not climb on or sit on the appliance.
- Do not use humidifiers in rooms with air contaminated with dust, microbes or chemicals.

2.3 Dangers posed by the humidifier

The humidifier is built according to the state of the art and current safety requirements. However, there are still residual risks that require prudent action. The residual risks and the resulting behavior and measures are listed below.

Electric current



DANGER! **Danger to life from electric current!**

Contact with active parts of the power supply unit poses an immediate danger to life due to electric shock. Damage to the insulation or individual components can be life-threatening.

- Keep moisture away from active parts. This can lead to a short circuit.
- Always disconnect the mains plug before cleaning and troubleshooting.
- Never immerse the device in water.
- Never point the outlet towards electrical appliances or sockets.
- Never touch the mains plug with wet hands. When pulling the mains plug, always pull on the plug, never on the cable.
- Always lay the mains cable so that it cannot come into contact with heat sources, moisture, oil, sharp objects, sharp edges, etc.

Special groups of people and children



WARNING!

Danger for special groups of people and children!

This appliance is not intended for use by persons (including children) with reduced physical, sensory or mental capabilities, or lack of experience and/or knowledge.

- Supervise children to ensure that they do not play with the appliance.
- Packaging materials must not be used for play. There is a risk of suffocation.
- Keep the aroma box away from children. There is a risk of suffocation.

Poor cleaning



WARNING!

Health hazard due to inadequate cleaning!

Inadequate cleaning can release bacteria and germs.

- Replace the evaporation filter after three months at the latest.
- Always observe the time intervals for cleaning, filter changes and water changes described in [Chapter "4.1 Cleaning and care"](#) on page 15.
- If the room air and water are heavily contaminated, shorten the time intervals accordingly.

Overhumidification



WARNING!

Health hazard due to overhumidification!

Over-humidified air encourages the formation of mold and harmful germs.

- Do not exceed the recommended value of 50 - 60 % humidity in living areas.
- To prevent damage to health, people with asthma, respiratory diseases or lung complaints should consult a doctor before using the humidifier.
- Do not place the appliance near furnishings that absorb water, such as curtains, wallpaper and carpets.

UV LED lamp



WARNING!

Risk of injury from UV light!

UV light irritates and damages the eyes and can cause skin irritation.

- Do not look at the UV lamp when it is switched on
- If the eyes are flashed, immobilize them by placing a wide, opaque bandage around them and take the injured person to the eye clinic

Unsuitable installation location



NOTE!

Risk of material damage due to incorrect positioning of the humidifier!

- Only install humidifiers on level, sufficiently stable and moisture-resistant floors.
- Do not place the appliance near furnishings that absorb water (e.g. curtains, wallpaper, carpets).

2.4 Environmental protection



NOTE!

Danger to the environment due to incorrect handling of environmentally hazardous substances!

Incorrect handling of environmentally hazardous substances, especially incorrect disposal, can cause considerable damage to the environment.

- Always observe the instructions below for handling and disposing of environmentally hazardous substances.

3. Transporting and commissioning

3.1 Transport and set up

- Only install humidifiers on level, sufficiently stable, moisture-resistant floors.
- Ensure that the air circulation is guaranteed. The intake and discharge grilles must not be covered.
- The distance to other objects in the surrounding area must be at least 10 cm to the side and at least 20 cm above.
- For optimum function, the appliance can be placed near a heat source. However, the direct temperature effect should not exceed 41 °C.

Transporting humidifiers



NOTICE! Risk of material damage due to tipping of the humidifier!

If the humidifier is moved, there is a risk of the appliance tipping over. This can lead to material damage to the appliance or the floor.

- Always empty the water tank before moving.
- Only lift the humidifier using the recesses provided above the tank to prevent damage to the appliance.

Fig. 3.1.1: Transporting the humidifier

Raising the humidifier



WARNING!

Danger when lifting the humidifier!

3.2 Preparing the humidifier for operation

Connection cable



Fig. 3.2.1: Rear panel with connection cable

Damaged connection cable!

If the mains connection cable of this appliance is damaged, it must be replaced with a special connection cable! This can be obtained from the manufacturer or your customer service.

NOTE!

Remove the protective film from the combi cleaning filter before usage (☞ see chapter "4.3 Changing the combi cleaning filter" Point no. 3 on page 17).

1. Check the connection cable for damage (Fig. 3.2.1/1).
2. Connect the device to the power supply, a signal tone sounds twice.
3. Switch on the appliance (☞ see chapter "3.3 Putting the humidifier into operation" on page 11).

Filling the water tank



Fig. 3.2.2: Filling the water tank

1. Remove the tank on the right-hand side of the appliance (see chapter 4.4 „Removing the tank“ on page 17).
2. Remove the rubber cap on the lower part of the tank (Fig. 3.2.2/1) to fill it.
3. Fill with water until you have reached the "MAX" mark
4. Replace the rubber cap and ensure that it is seated correctly.
5. Reinsert the tank.

NOTE!

Risk of material damage due to overfilling the humidifier!
Fill the tank up to the mark and not beyond!

Water fresh (optional accessory)

Waterfresh can also be added to the water tank to reduce the formation of germs, algae and limescale deposits. Observe the dosing, use and disposal instructions on the Waterfresh packaging. The water freshener can be obtained from our customer service department (☞ "Customer service" on page 2).

Order numbers: 1l bottle: 9020; 5l canister: 9022;





NOTE!

Environmental damage due to biocides! The biocides contained in Wasserfrisch are harmful to the environment in large quantities.

- Use biocides safely.
- Obtain information on environmentally friendly disposal from the local municipal authority or special waste disposal companies.
- Always read the label and product information before use.
- Safety data sheet can be requested.

3.3 Putting the humidifier into operation

Switching on the humidifier	Press the STANDBY button  . + Humidifier is switched on. The upper LED lights up white.
Standby	Press the STANDBY button  . + Humidifier is on standby. The upper LED is deactivated.
Switch off	To safely switch off the humidifier during maintenance or long-term shutdown: + Pull out the plug & disconnect the humidifier from the power supply.

Overhumidification



WARNING!

Health hazard due to overhumidification!

Over-humidified air promotes the formation of mold and harmful germs.

- Do not exceed the recommended value of 50 - 60 % humidity in **living areas**.



To use the device in humidifier mode, please press the humidifier button  and fill the water tank beforehand (see „Filling the water tank“ on page 10). Without pressing the humidifier button , the device is used as an **air purifier**. The LED light strip indicates the current air quality. Green stands for very high air quality, blue for medium air quality and red for poor air quality (Fig. 3.3.1). It takes approx. 60 seconds to determine the air quality, during which time the LED lights up alternately in the three colours.



Fig. 3.3.1 Recognizing air quality using the LED strip light

Setting the relative humidity

The target value for the relative humidity can be set in the range from 30 % to 85 %.

+ Use the HUMIDITY + button  and HUMIDITY -  to set the desired target value for the relative humidity. Increase the value by 5% each time you press the button.

→ The display shows the selected value.

+ As soon as the target value is reached, the appliance switches off automatically and the LED of the humidifier button  flashes.

Setting the fan speed

The air flow rate and thus the humidifier output can be adjusted via the fan speed, for example: select a higher fan speed for large rooms.



+ Use the FAN button  to set the desired speed level from the 4 fan levels.

→ The display  above shows the selected speed level.

→ The humidifier runs at the selected fan speed until the desired value for relative humidity is reached. The appliance does not switch off in air purifier mode.

Automatic fan operation



In automatic mode, the humidifier automatically regulates the fan speed depending on the power requirement until the desired relative humidity value is reached.

1. Select the target value for the relative humidity using the HUMIDITY +  or HUMIDITY -  buttons.
2. Press the AUTO MODE button .
+ Automatic mode is switched on.





+ To exit automatic mode, press the FAN button  and set the desired fan speed.

Silent mode

In silent mode, the humidifier runs at the lowest fan speed and the LEDs of the displays and the display switch off to avoid disturbing factors.



1. Press the AUTO MODE button  twice in succession.
+ Sleep mode is switched on.
2. Press the AUTO MODE button  again.
+ Sleep mode is switched off.

Switching the key lock on and off

1. To activate the button lock, press and hold the Humidity +  and Humidity -  buttons for approx. 5 seconds.
+ The key lock is activated as soon as the signal tone is heard.
2. To deactivate the button lock, press and hold the Humidity +  and Humidity -  buttons for approx. 5 seconds.
+ The key lock is deactivated as soon as the signal tone is heard.

UV LED lamp

Switch on the integrated UV LED lamp to utilize the germ-reducing effect of the device.

1. To switch on the UV LED lamp, press the  button.
+ The UV LED lamp is activated.
2. To switch off the UV LED lamp, press the button .
+ The UV LED lamp is switched off.



Deactivate display

You can use the display OFF button  to switch off the LED indicators and the display. This may be necessary at night when operating in the bedroom, for example, to avoid disturbances. All other settings such as fan speed, humidifier or purifier mode remain active.

Timer

If you would like to use the timer function, please press the TIMER button . You can choose between a value of 00 and 12 hours. The time can be set in 1 hour intervals. Once the set time has elapsed, the appliance switches off.

Filter change reminder

After an operating time of approx. 600 hours, the FILTER CHANGE indicator  lights up. Check the filter for dirt and replace it if necessary. Change the filter  see chapter „4.5 Changing the evaporation filter“ on page 18. Then reset the display by pressing and holding the FILTER CHANGE button  for 3 seconds.

Aroma box



The humidifier has an aroma box that allows you to use suitable fragrances by placing them on the air outlet grille and releasing their aroma into the air. Only use the aroma box and aroma pads provided by Brune (included in the scope of delivery). Further aroma pads (order number: 2070) are available from via our customer service (👉 "Customer service" on page 2). Only apply a small amount to the pad, 1 - 2 drops are sufficient.



WARNING!

Do not use any aroma or fragrances outside the designated flavoring box!

Wifi

To use the Wifi function, press and hold the  button for 5 seconds. The Wifi symbol now starts to appear on the Display  flashes.



Tuya Smart

Tuya Smart Inc.
In-App-Käufe

Installieren



Download the Tuya Smart WiFi app to enable control via the app. Registration is required to use the app. If you already have an account, you can use your existing account.

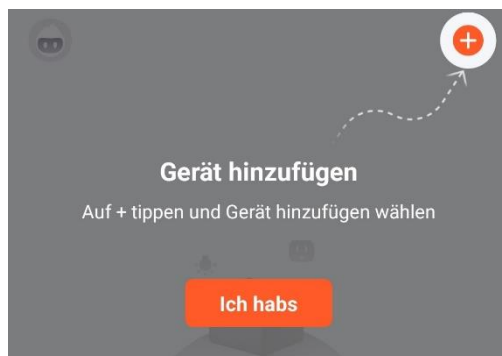

Follow the instructions in the app and add a new device. The device should be automatically suggested after pressing the Wifi button. Now select the device to pair it with the app.



Select the existing network and enter the password to gain access to the device.

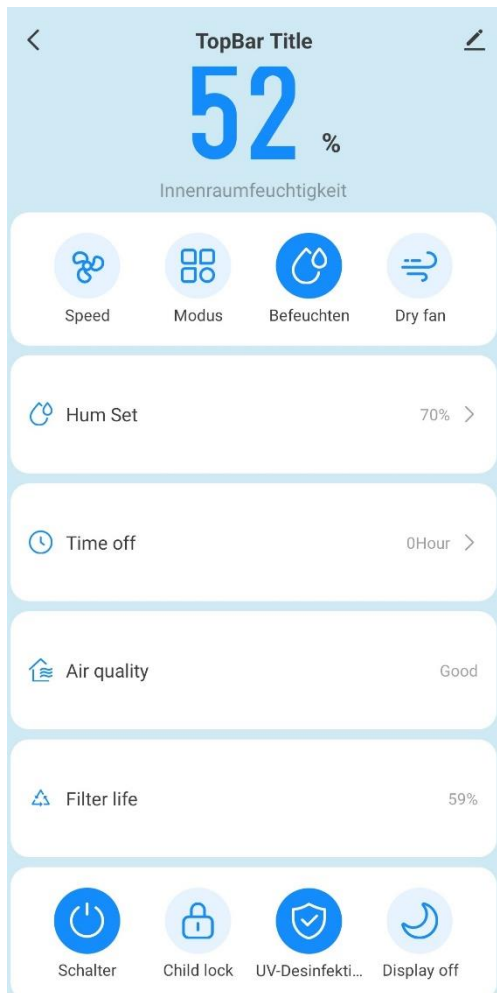

As soon as the device is paired, you can make the following settings via the app:

1. Select fan speed
2. Choose between manual control and automatic or sleep mode
3. Humidifier or air purifier mode
4. Dry fan (max. fan speed)
5. Target humidity
6. Timer
7. Switching the device on and off
8. Switching the key lock on and off
9. Switching the UV lamp on and off
10. Switching the display on and off

In addition to the above settings, you can also read off the air quality and the service life of the filter as a percentage.

4. Cleaning and care

4.1 Maintenance table

Maintenance work

The frequency of maintenance work depends on the air and water quality at the installation site. If necessary, adjust the maintenance intervals recommended here.



WARNING!
Disconnect the appliance from the power supply before carrying out maintenance work.



WARNING!
Risk of injury from moving parts! Rotating fan wheel can cause hand injuries.

Interval	Maintenance work
At least weekly	Change the water and clean the tank (↪ see chapter „4.6 Changing the water and cleaning the appliance“ on page 19).
At least monthly	Clean the inner side panels and float with a damp cloth (↪ see chapter „4.6 Changing the water and cleaning the appliance“ on page 19).
At least every 3 months	Change the evaporation filter (↪ see chapter "4.5 Changing the evaporation filter" on page 18).
As required	Change the combi cleaning filter (↪ see chapter "4.3 Changing the combi cleaning filter" on page 17).
At least once a year	Carry out basic cleaning with limescale remover (↪ see chapter „4.6 Changing the water and cleaning the appliance“ on page 19).

4.2 Opening and closing the intake grille

The intake grille must be opened for the following work:

- Change the combined cleaning filter.



Open intake grille

1. The intake grille is attached to the left and right side of the appliance using plastic hooks.



Fig. 4.2.1 Opening the intake grille



2. Lift the intake grille at the top of the grille. Use the existing handle to do this.
3. Now slide the intake grille upwards to remove it and place it on its side (Fig. 4.2.2)
4. Now change the filter (↪ see chapter "4.5 Changing the combi cleaning filter" on page 17)

Fig. 4.2.2: Removing the intake grille

Close intake grille

1. Replace the intake grille in the recess after changing the filter.
2. On the right and left side of the appliance you will find notches in which the plastic hooks must be inserted (Fig. 4.2.3).
3. Press the intake grille down slightly to secure it in the notches.



Fig. 4.2.3 Closing the intake grille

4.3 Changing the combi cleaning filter



Fig. 4.3.1: Removing the combi cleaning filter



WARNING! Risk of electric shock if the mains plug is not disconnected!

Disconnect the appliance from the power supply before starting.



NOTE!

Remove the protective film from the combi cleaning filter before usage

You can obtain the appropriate combi cleaning filter (order number: 2080) from our customer service department (↪ "Customer service" on page 2).

1. Open the intake grille (↪ see "Opening the intake grille" on page 15).
2. Pull the used combi cleaning filter out of the appliance by the upper tab (Fig. 4.3.1).
3. Remove the protective film from the combi cleaning filter.
4. Now insert the new combi cleaning filter.
Make sure that the filter is positioned correctly to ensure proper function.
5. After successfully changing the filter, close the intake grille again (↪ see "Closing the intake grille" on page 16).

4.4 Remove tank

The tank must be removed for the following work:

- Fill tank, clean tank, clean inner side walls, change evaporation filter, clean float.



WARNING! Risk of electric shock if the mains plug is not disconnected!

Disconnect the appliance from the power supply before starting.



Fig. 4.4.1: Removing the tank

1. Reach into the recess above the tank and pull the tank out. It should now be at a slight angle.
2. Now lift the tank to remove it from the housing (Fig. 4.4.1).
CAUTION: Allow the tank and the internal drip tray to drain slightly before removing it.
Avoid dripping water as far as possible. Use a dry cloth if necessary. Carry out this work in a suitable place, such as a sink, as water may escape.



Fig. 4.4.2: Removing the drip tray

NOTE!

Caution, risk of tipping!

Risk of material damage due to escaping water.

+ When removing the drip tray, make sure that it does not tip over.

3. Reach under the drip tray and carefully pull it out, including the filter holder (Fig. 4.4.2).

CAUTION: Allow the drip tray to drain slightly before removing it. Avoid dripping water as far as possible. Use a dry cloth if necessary.

4. You can now carry out further cleaning work on the appliance.
5. Once maintenance is complete, replace the drip tray and tank correctly.

4.5 Changing the evaporation filter



WARNING! Risk of electric shock if the mains plug is not disconnected!

Disconnect the appliance from the power supply before starting.

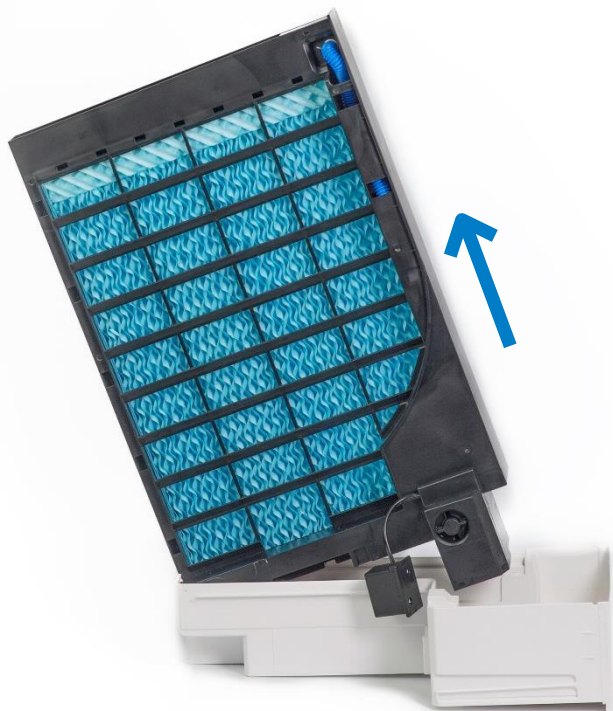

Fig. 4.5.1: Removing the filter carrier

You can obtain the appropriate evaporation filter (order number: 2090) from our customer service department (☞ "Customer service" on page 2).

1. Remove the tank and the drip tray (☞ see „Removing the tank“ on page 17). Carry out this work in a suitable place, such as a sink, as water may escape.
2. Remove the black plug connection to be able to remove the filter holder.
3. Lift the filter holder on the right side and pull it upwards out of the drip tray (Fig. 4.5.1).

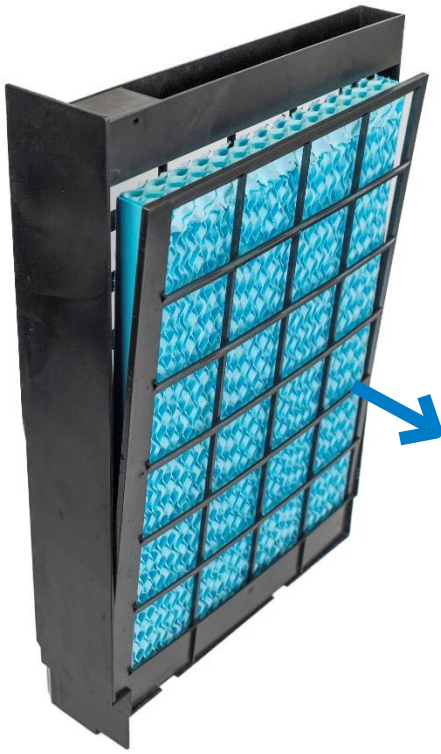
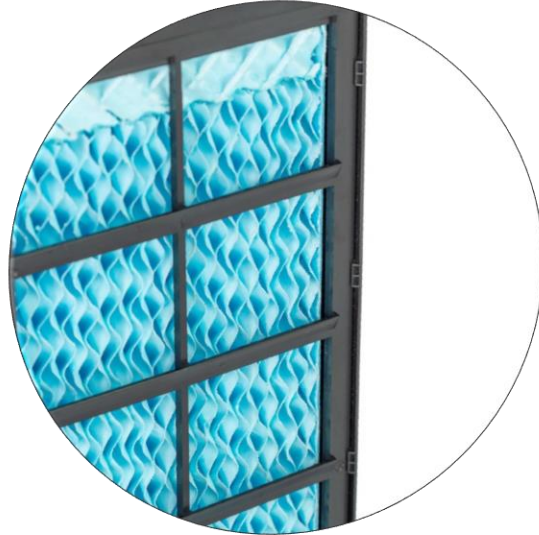

Fig. 4.5.2: Removing the grid of the filter carrier

4. Remove the grid of the filter holder (Fig. 4.5.2).
5. Dispose of the old evaporation filter and insert the new one. Make sure that the filter is positioned correctly to ensure proper function.
6. Replace the grille of the filter holder. Make sure that the grille is properly secured by the plastic device.
7. Reinsert the parts in reverse order.



4.6 Changing the water and cleaning the appliance

In case of heavy soiling and limescale, use a limescale remover for cleaning. You can obtain a suitable limescale remover from our customer service department (☞ 'Customer service' on page 2). Observe the dosing and application instructions on the packaging of the limescale remover (order number: 9016). Carry out this work in a suitable place, such as a sink, as water may escape.

1. Pull out the water tank
2. Pull out the drip tray with filter holder.
3. Empty the water tank and drip tray.
4. Clean the water tank and drip tray incl. float with a damp cloth.
5. Clean the inside walls of the humidifier with a damp cloth.
6. Change the evaporation filter (☞ see chapter 4.5 "Changing the evaporation filter" on page 18).
7. Insert drip tray with filter holder.
8. Fill the water tank (☞ see 'Filling the water tank' on page 10).
9. Insert the water tank.



WARNING! Risk of electric shock if the mains plug is not disconnected!

Disconnect the appliance from the power supply before starting.



NOTE!

Do not use abrasive, corrosive or soapy cleaners. May damage the surface of the appliance.

6. Solve problems

Error code display

If the operation of the humidifier is faulty, an error message appears in the display field.



Error number	Description	Remedy
E2	Error with the humidity sensor	Contact customer service (↪ "Customer service" on page 2).
E5	Error with the WiFi module	Contact customer service (↪ "Customer service" on page 2).
E6	Error with the automode / sleep mode	Contact customer service (↪ "Customer service" on page 2).
	Water tank empty	Fill the water tank (↪ see 'Filling the water tank' on page 10).

Other faults	Remedy
Water leakage	<ul style="list-style-type: none"> ■ Pull out the mains plug. ■ Empty the water tank. ■ Mop up any leaked water as quickly as possible to prevent damage to the floor. ■ Check the water tank for damage. ■ Contact customer service (↪ "Customer service" on page 2). ■ Check that the evaporation filter is positioned correctly (↪ "Changing the evaporation filter" on page 18).
Severe calcification	<ul style="list-style-type: none"> ■ Clean the humidifier more frequently (↪ „Changing the water and cleaning the appliance“ on page 19). ■ Use limescale remover for cleaning (↪ „Changing the water and cleaning the appliance“ on page 19).
Odor development	<ul style="list-style-type: none"> ■ Change the water more frequently (↪ „Changing the water and cleaning the appliance“ on page 19). ■ Clean the humidifier more frequently (↪ „Changing the water and cleaning the appliance“ on page 19). ■ Use fresh water (↪ „Fresh water“ on page 10). ■ Replace the filter (↪ „Replacing the evaporation filter“ on page 18).

Repairs

Repairs may only be carried out by the manufacturer's customer service department (↪ "Customer service" on page 2) or trained electricians.

7. Spare parts

Here you will find a list of common spare parts:

Article description	Item no.
Evaporation filter for humidifier B 200	2090
Combi cleaning filter for humidifier B 200	2080
Pads for Aroma Box	2070
Waterfresh 1l bottle	9020
Waterfresh 5l canister	9022
Limescale remover 1000 ml	9016

8. Type plate



The nameplate contains the following information:

- Brand
- Model number
- Electrical power and connected loads
- Batch number
- Manufacturer

9. Disposal

If no take-back or disposal agreement has been made, disassembled components must be recycled:

- Scrap metals.
- plastic elements for recycling.
- Dispose of the remaining components sorted according to material properties.
- Have electronic waste and electronic components disposed of by authorized specialist companies.
- If in doubt, obtain information on environmentally sound disposal from the local municipal authority or specialized disposal companies.



ENVIRONMENTAL PROTECTION!
Danger to the environment due to incorrect disposal!
Incorrect disposal can pose a risk to the environment.





Luftbefeuchtung Proklima GmbH
Schwarzacher Str. 13
74858 Aglasterhausen
Germany

Phone.: +49 (0) 6262 / 5454
Fax: +49 (0) 6262 / 3255

Mail: mail@brune.info
Web: www.brune.info